

ERZMO[®] MS 1

Best choice for the final mile

The pedelec-engine for cargo-bikes

36 / 48 V battery voltage
integrated 3-way gearshift
meets pedelec standard

Made in Germany



Elektromotorenwerk Grünhain GmbH

Bahnhofstraße 12 | D-08344 Grünhain-Beierfeld

Telefon +49 (0) 3774 52-200

Telefax +49 (0) 3774 52-215

e-mail info@emgr.de

Internet www.emgr.de



ERZMO[®] MS 1

Description

The ERZMO[®] MS 1 by EMGR is a powerful mid-engine line with is drafted especially for cargo-bikes. With its outstanding torque performance loads up to 300 kg can be easily moved.

The ERZMO[®] drive has a long life and robust construction and is especially designed for heavy industrial usage. The integrated 3- Shaft gearbox allows an individual dosing of the necessary driver effort. An integrated high performance electric system controls the drive in all situations.

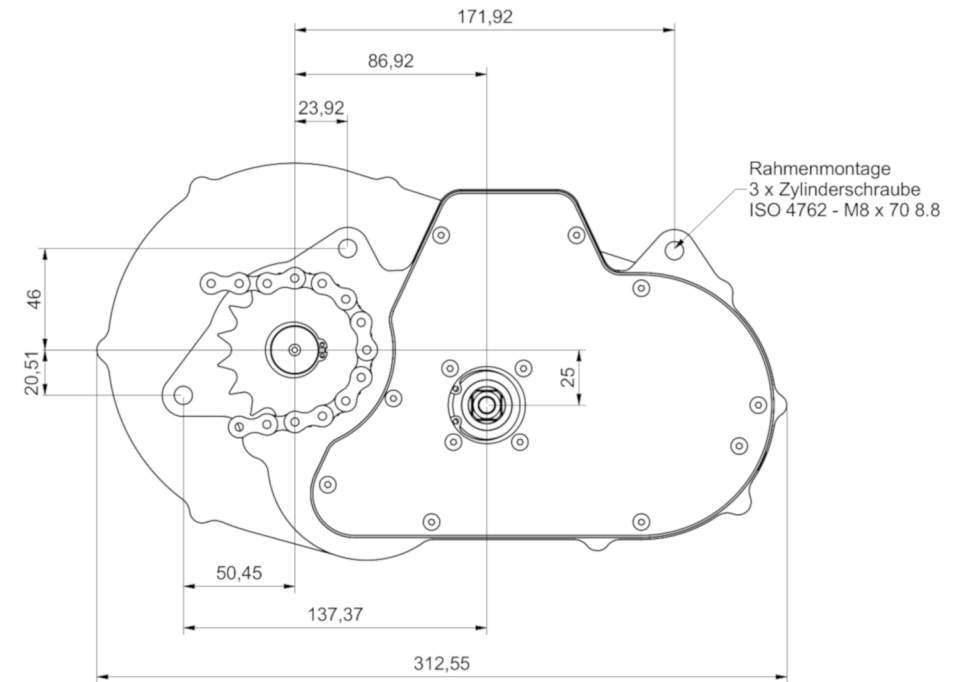
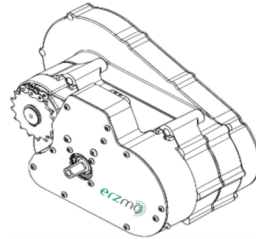

Technical Data

DC supply voltage	36 V or 48 V
Rated power	250 W max. 600 W
Nominal current	7 A 8 A
Starting support	up to 6 km/h
Speed limit	25 km/h
transmission	3-Shaft gearbox (integrated)
Operating temperature	-20°C till 60°C

